

MISC. SPX STORYBOARDS
FROM

H.P. LOVECRAFT'S
THE
RE-ANIMATOR

1

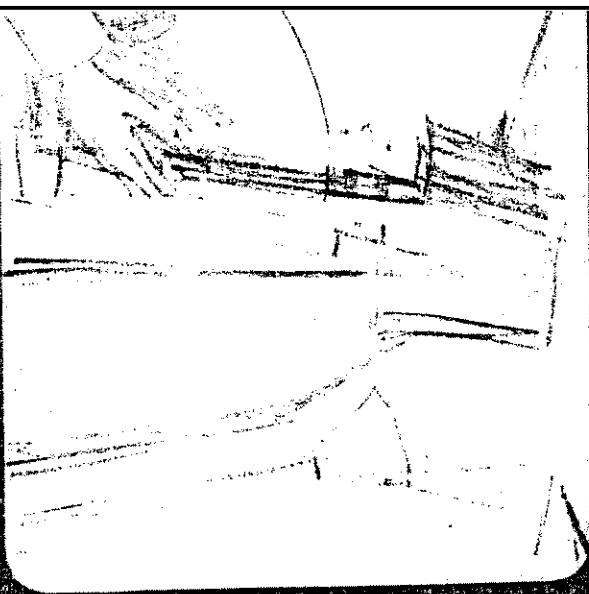

5969

Worst reaches behind
and grabs the handle
of a shovel

4

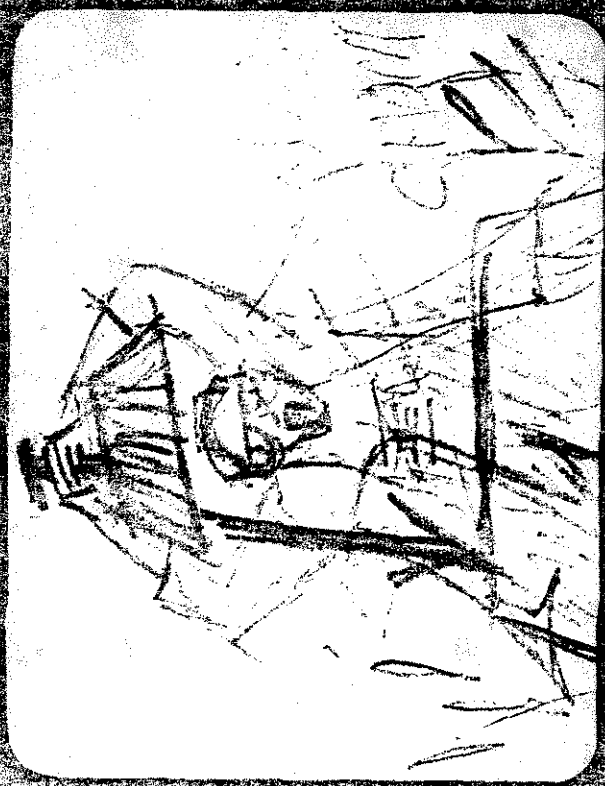

sc 69

West runs over being
bringing the shovels edge
down on Hills neck.

3



sc 69

Halsey crashes to the floor

6



b9 35

West has his foot on the
should pushing down until



b9 35

There is a loud snap and
the head separates from
the body

1

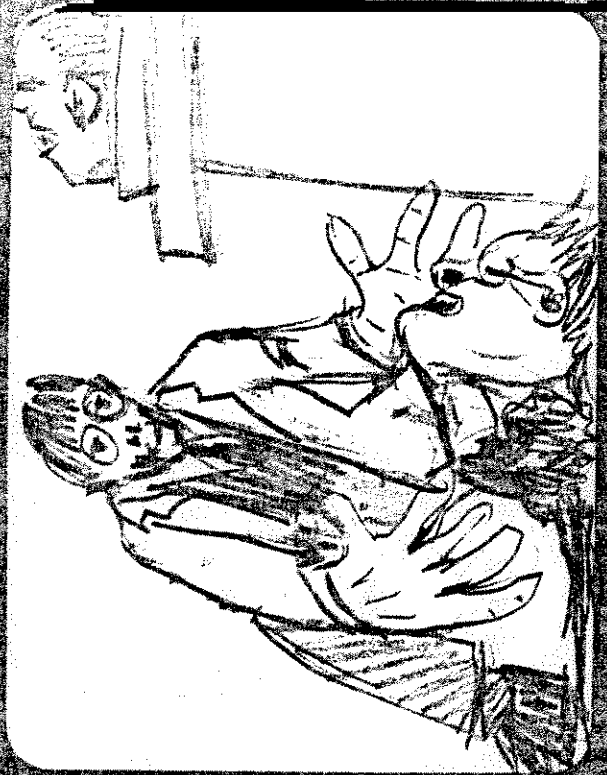

Sc: 71

pg 69

West is laughing to himself
 He bends down - and lifts
 up Hill's head. He puts
 the head in a tray.

2



Sc: 71

pg 69

Then he looks at the
 headless body. West looks
 back at the head. He
 smiles broadly
 West: Yes.

3



Sc 71 pg 70

He fills a hypo with the Re-animating Serum West: Parts. I've never done whole parts. (Serum glow on (use))

4



Sc 71 pg 70

He injects the skull at the base of the brain.

5



Sc 71

pg 70

West injects the scream into the heart.

West: This should be interesting

5



Sc 71

pg 70

He sits on a stool opening notebook and watches the head.

He taps out three seconds with a pencil, tapping the head after a while.

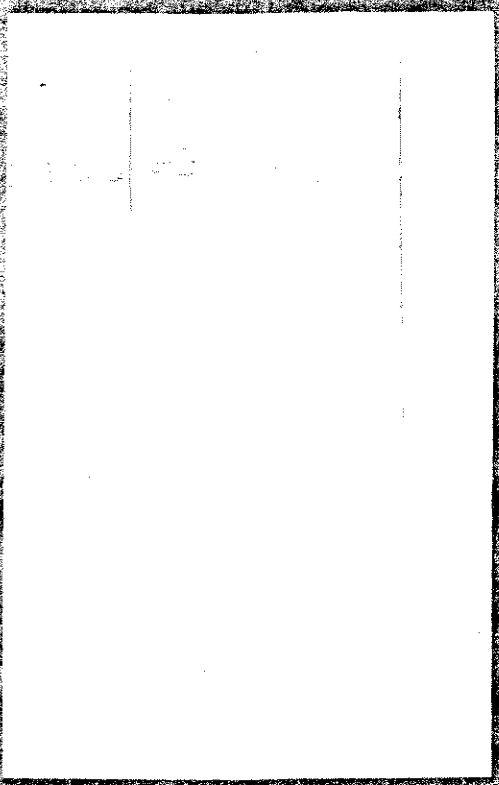
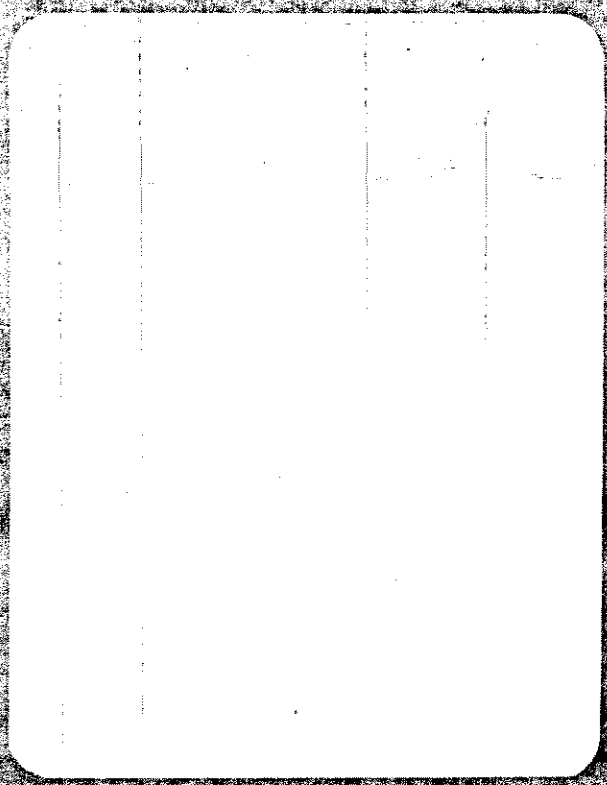

sc 71 pg 70
The eyes pop open

1



Sc 71

pg 70

Yes doctor, it's me Herbert West.

2



Sc 71

pg 70

The body lurches to its feet and grabs West by the shoulders.

1



Sc 85 Start wide on room ppl
Zoom into this

Wide shot of Autopsy Room
filled with several bodies on
gurneys. Slow zoom in on
Hill who is drilling yet another
corpse as Hill's head directs.
There is uncoordinated pounding
at the rear door. Hill's head look

2



Sc 85

pg 81

Hill's body blindly moves in way
to the exit + clumsily opens
the door letting in Halsey
carrying Meg. The door slams
behind them

3



Sc 85

Hill smiles.

Hill: Yes Allan

Pg 81

4



Sc 85

Halsey places Meg on a table and looks to Hill who nods. Halsey reaches out and tears the night gown from Meg's body.

Hill: Yes Halsey retreats to the corner.

Pg 81

6

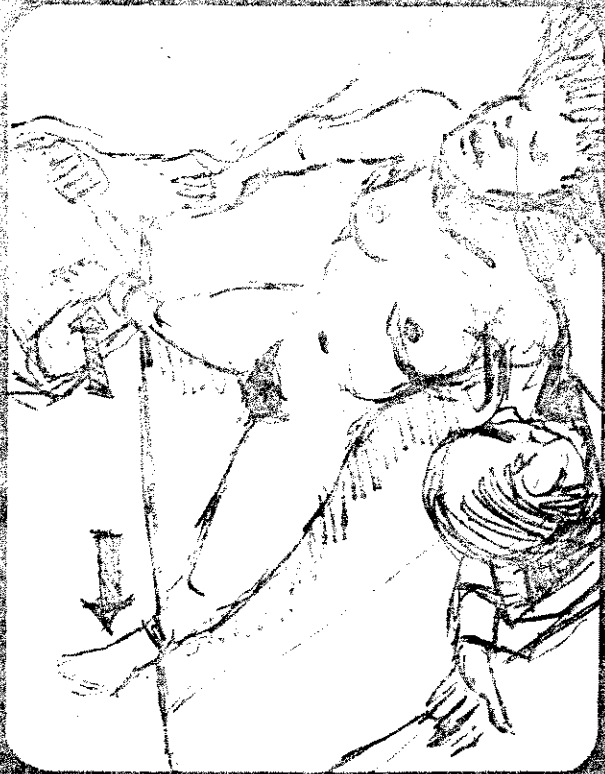

pg 81

Sc 85

5



pg 81

Sc 85

The body steps forward and straps Meg down

8



186d

5825

Hill smiles

7



186d

5825

Hill's body doesn't notice that one arm strap is not secure

2



Sc 87

Pg 82

Hill's head, its expression, hums and moans in pleasure
Hill: Meg ← Meg —

1



Sc 87

Pg 82

Hill's body is stroking Meg's nude form.
odd long establishing shot before this

5



Sc 87

Pg 82

Meg knocks her phone out from the shoulders of her body. She screams loudly.

3

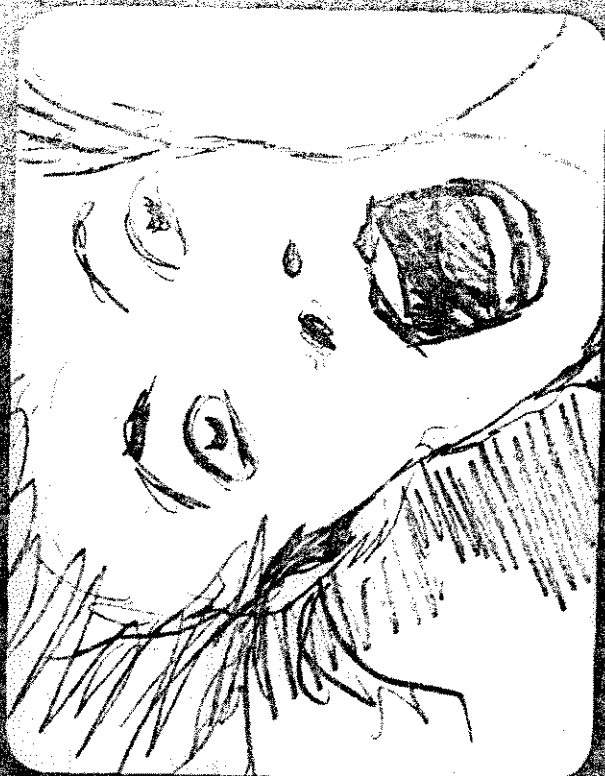

Sc 87

Pg 82

Meg stirs, then awakens, then screams.

6



Sc 87

Hill tonight

4

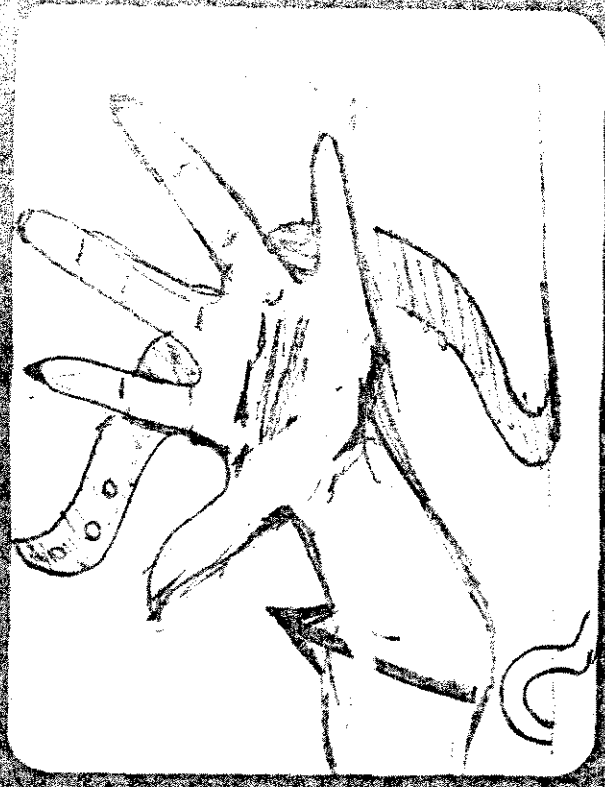

Sc 87

pg 82

Meg tears her arm free.
(between last 2 shots)

8



Sc 87

The eyes shine, eyebrows and
 Hill: I'm sorry you have a headache
 like this etc

add close ups of Meg ~~looking~~ and
 and Hill with eyes shining.

7

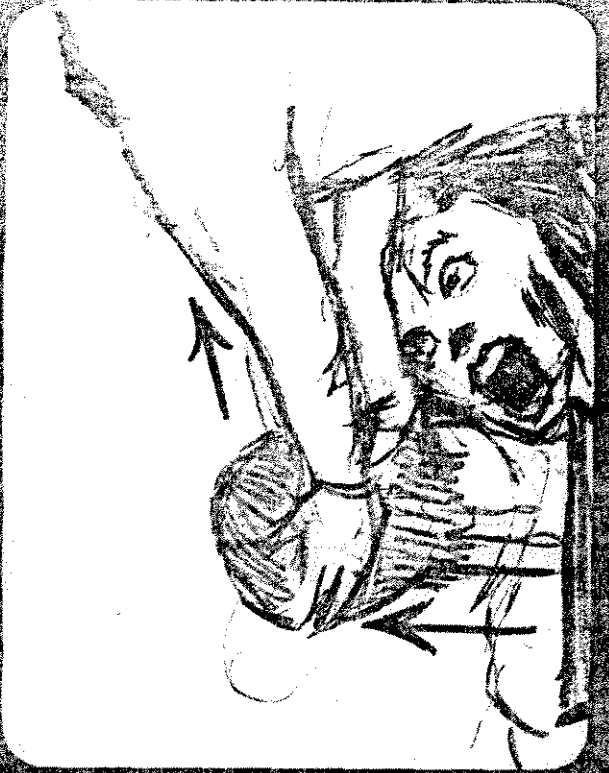

Sc 87

The body lifts the head
 and holds it over Meg
 for a better look.

9



10



Sc 87

Meg:
Please-let me go
Hill:
I can't do that my dear. You
see I need you, near me.

pg 82

Sc 87

The Head comes closer to
her face manouvered by the staff.
I've admired your beauty
for years now--
But I think I've always
loved you.

12



Sc 87

0783

Then it kisses her neck
The bleeding stump disappears
Hill and you will love me

11



Sc 87

pg 82

It lowers its lips to her's but
she turns her head away
The Head kisses her ear,
pressing its tongue into
it. She screams.

14



Sc 87 PJ85
 Meg:
 Oh God, oh God.
 Yes, my love.
 West:
 I must say Dr. Hill -
 The head looks up

13



Sc 87 PJ85
 Hill:
 You will,
 He kisses her breast. She winks
 Meg: Please, please stop. Let me go.
 That's it my dearest Meg,
 more passion.
 It kisses her stomach

16



Sc 87

1785

Ah, Mr West. I'm actually glad to see you. It saves me the trouble of - sending for you.

15

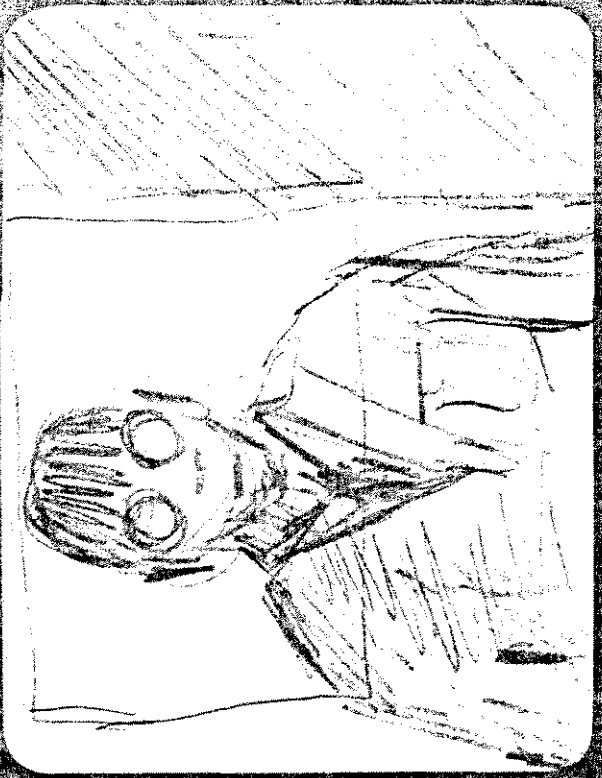

Sc 87

1785

West: I'm very disappointed. You steal the secret of life and death etc.

17



Sc. 87

pg 86

West approaches, taunting him
West: You'll never get credit for my
discovery now. Who'd believe a
talking head. Get a job in a
side show.

18

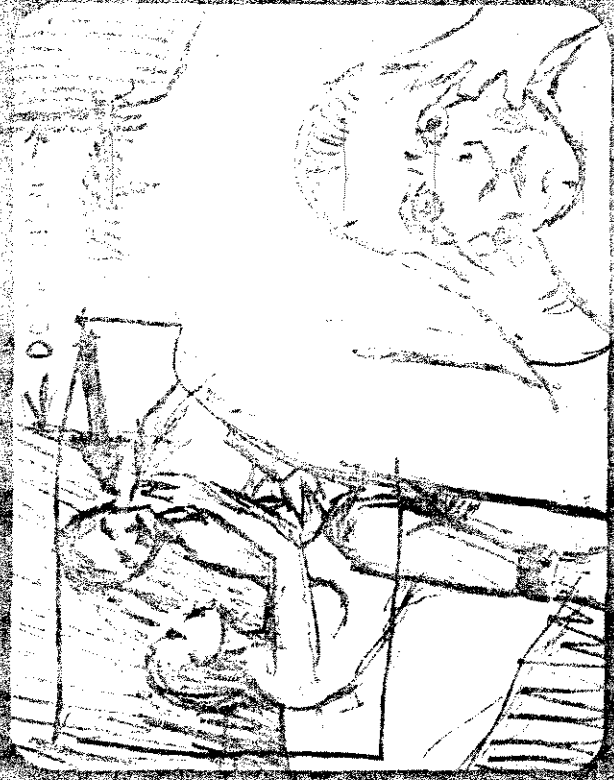

Sc 97

pg 84

Hill: Soon a surgeon here-etc
Reavixir door opens, Ray enters.
He sneaks over to the ceiling Men,
motioning her to be quiet. He strips
her and lifts her from the table
as Hill keeps talking.
Hill: I wonder why you
intelligent young man-etc

20



Sc 87
18 25

Hill so do l.

19

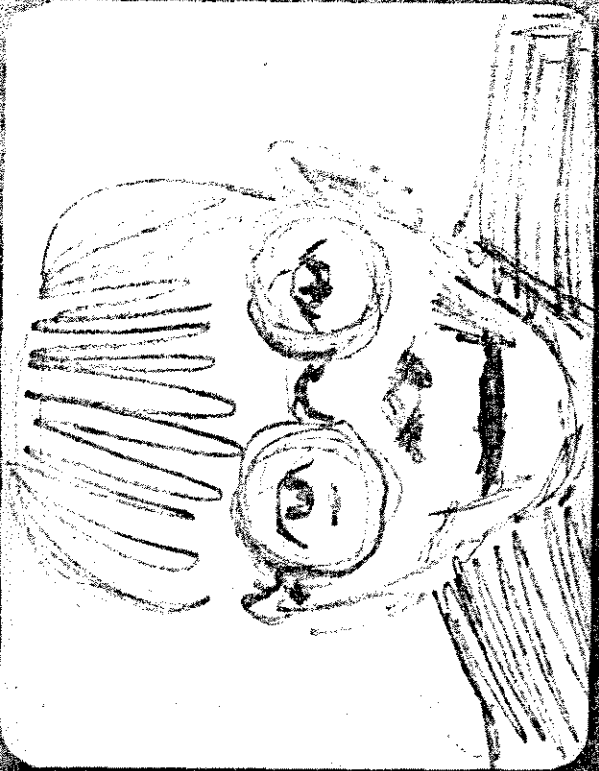

Sc 87
18 24

West: Oh, I have a plan

22



Sc 87

pg 89

shots of corpses tearing
off garbage bags
(This one is bullet wound to
the face.)

21



Sc 87

pg 84

Suddenly all the corpses in the
room sit up. Meg screams as
the corpses tear off the black
plastic garbage bags which
cover them

24



Sc 87

186A

A corpse pulls Meg's
leg (Meg's Pan.)
(child - car crash)

23



Sc 85

186B

A corpse grabs Pan by the
throat
Meg looks down

25



Sc 87

17/88

West draws a syringe from his pocket and moves towards camera

26



Sc 85

17/88

West charges Hill. The body spins the head in its hands so it can see behind the body back.
(moving camera or zoom)

28



sc 87

p984

Dan is being pounded by 3 re-animated corpses while Meg horrified is restrained by the others

27



sc 87

p984

Holding the head by the hair with one hand, the body grabs West by the wrist with the other and forcing him to drop the syringe. The body twists West's wrist until he is kneeling on the floor in pain (Add close-ups of West in pain)

30



1884
 Hill: Enough!

29



1884
 Hill throws West to the floor

32

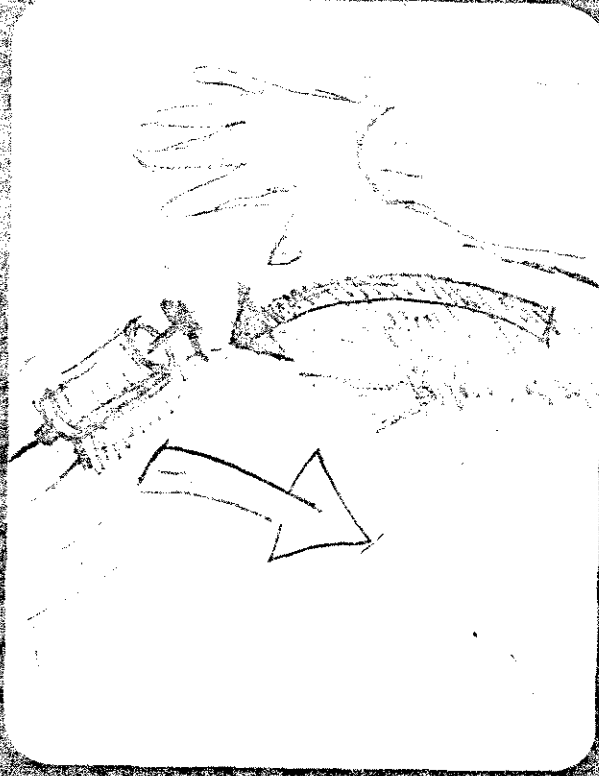

p985

Sc 87

Hills body picks up
hypo wast dropped

31



p984

Sc 87

Corpses drop Dan who dumps
to the floor catching his breath
Meg is released and runs to
Dan kneeling over him
protectively

34



Sc. 67 pg 85

West: I have a change

33



Sc. 67 pg 85

and holds it before the board for inspection

Hill: This is your - my - sorry, Mr. West. Was that your plan? What did you hope to accomplish?

36



sc 87

pj 85

Hills body puts the head and fingers and snaps its fingers. Two of the corpses grab West by the arms and hold him up. Hill.
 History pretends to know discerning men of ideas. But what it really projects is power.
 Hills body slowly approaches West as the

35



sc 87

pj 85

Hill: I'm sure you do. And yes Mr. West I plan to steal it, too.

38



"Reanimated subjects have power
to be the best there will be
Cyrus and those going strong
Close up on the face
Hill talks zoom in on
laser hole

37



sc 87
Hill
I will show you power

39



Sc 87
The corpses drag West out of the
autopsy table on Hill activates
the laser drill. West saves at
Hill with loathing.

Hill: Too bad you have such
a strong will, Herbert, etc.

1



Sc 87A

1986

Hill: Then I'll give her life.

My gift to her.

The laser beam begins to burn into
West's flesh, smoke begins
to rise. West still glares.
Hill laughs, insanely.

2



Sc 87B

p987

Hill's body discards the laser drill which beams wildly across the room.

1



Sc 87B

p987

Hill's head sees Halsey cranking towards him.

4



Sc 87B
9/2

Hills body struggles
Halsey

3



Sc 87B
9/2

West, a hole burnt to the bone
drops the stove and begins to
struggle with the two corpses
that are restraining him

add biting
leg

5



Sc. 92

p. 87

The Head contorts in a
pained grimace

6



Sc. 93

p. 87

Halsey + Hill's Body overboard in
desperate struggle. With a cry, Halsey
flings the Body out
Room door to the basement
corridor.

2



Scene 95

17.8

as Halsey picks it up

1

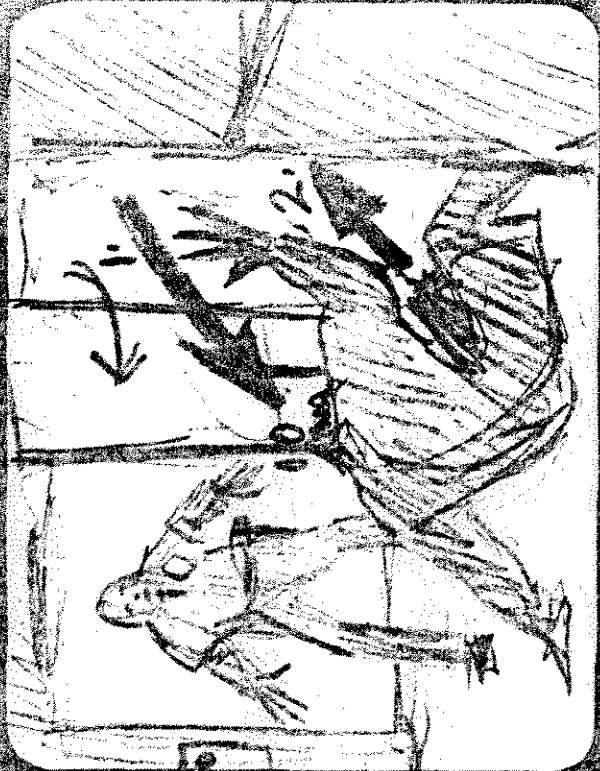

Sc 94

pg 88

Mace gets out of the elevator and
 sees Hille Headless Body career blindly into
 the corridor. To Mace's amazement
 the Headless Body gets up and
 re-enters the autopsy room
 innercut CU on Mace

3



Sc 95 P 988
and squeezes it

1



Sc 95 P 986
Hills head screams in anguish

5



Sc 95

Halsey butts the head with
his own head and
squeezes it again

4



Sc 95

while Hills body finds it's
way through the chaos.
(Hand held shot following Hill)

1



sc 96 pg 88

Halsey pokes his fingers into
Hills eyes pulling them out
one after another

6



sc 95 pg 88

The corpses tearing at West
grab their own heads in
realization

2



Sc 96
 1788
 Wail of anguish rises from all
 the re-animated corpses
 Wierd close ups on corpses
 ... grabbing their eyes
 They begin to flail wildly ingoring
 Dan and Meg

3



Sc 96
 1788
 Hill's head screams as Halsey's fingers
 with his fingers in the bloody
 sockets. Then Hill's Body blindly
 leaps on Halsey's back, strangling
 him

2



Sc 99 West:
 I told you I have a rough
 He pushes the Hippo plunger and
 Serum squirts from the needle.
 He fills another,
 West:
 Overdose!

1



Sc 99
 Hill's Body is choking
 still grips the Head. which
 laughs horribly in his face.
 West enters quickly filling
 a large syringe.

4



SC 99 West! 1957
 200 cc's of re...
 injected at (chest...
 watch.) 11:57 PM.
 Cut to shot of Body and
 then back to this in C.U.
 West!
 Immediate reaction! (was
 right!)

3



SC 99 1957
 West runs up behind Hills
 Body and injects both bypos
 deep in the Body's abdomen.
 Then breaks off the needles
 in the flesh

6



sc 99
pg 29

5



sc 99
pg 29
An awful cry comes from Hills
Head or Halsey squeezes the
skull to the cracking point (sound
effects)

8



sc 99
bb 35
Halsey throws the
head with all his
might

7



sc 99
bb 35
and beyond

2

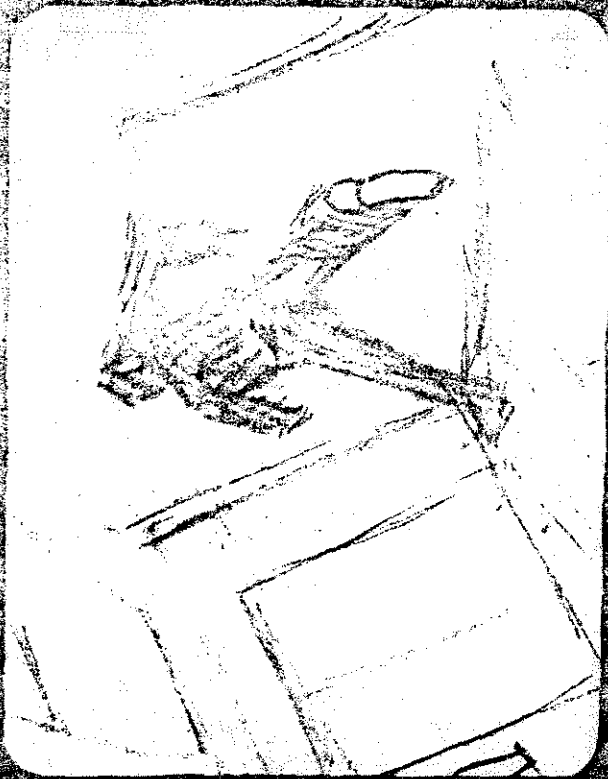

Sc 1100

pg 81

then runs toward the
hall for help

1



Sc 100

pg 81

Maree looks into the Autopsy Room
Just as Hill's Head comes flying
out and hits the corridor wall.
It slides, a flat, limp bag, down
the wall. Maree watches, incred-
ulously.

2

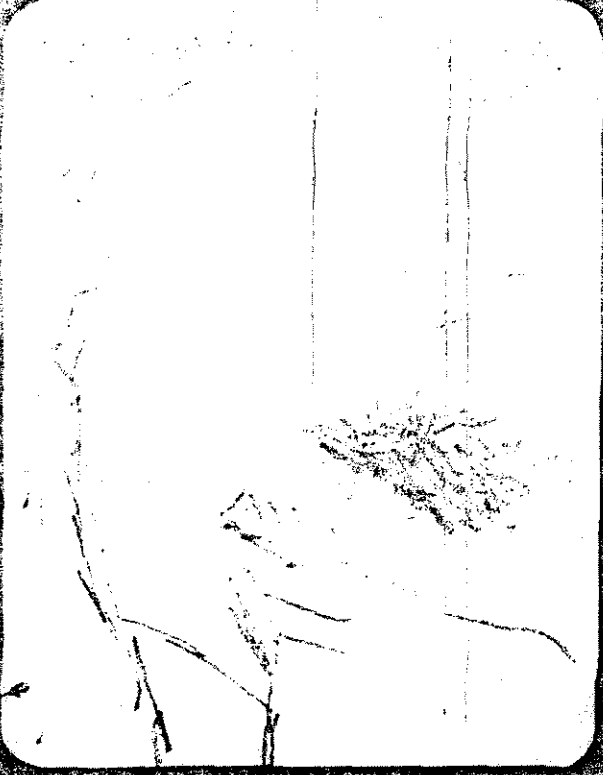

Sc 101

There is a small
blood stain
(blood stain of ...)

1



Sc 101

Every roll of the body is
into an occ. forward
quiver

4



Se 101

The intestine shoots
out and wraps
around the liver

3



19.59

Se 101

The intestine jabs
out. Tearing through
the abdomen, ripping out

6

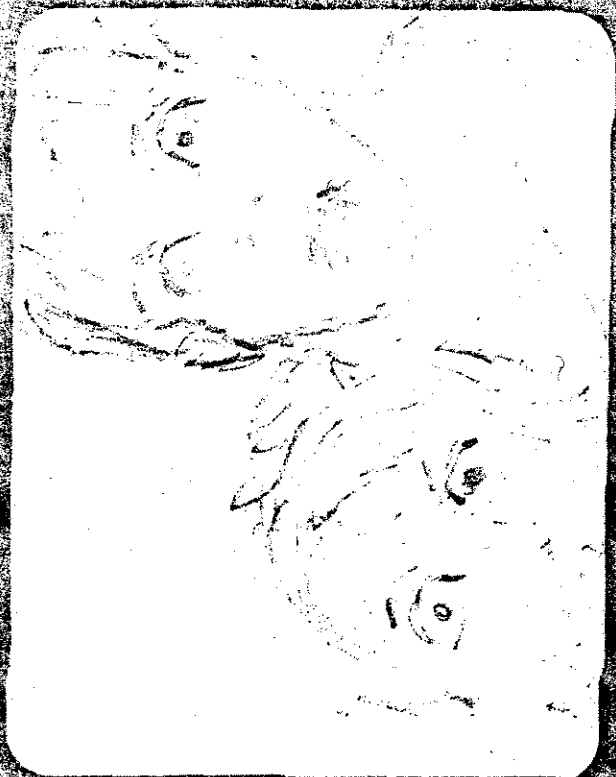

Se. 101

Mfg and Draw

5



Se. 101

First is pulled out of the frame

8

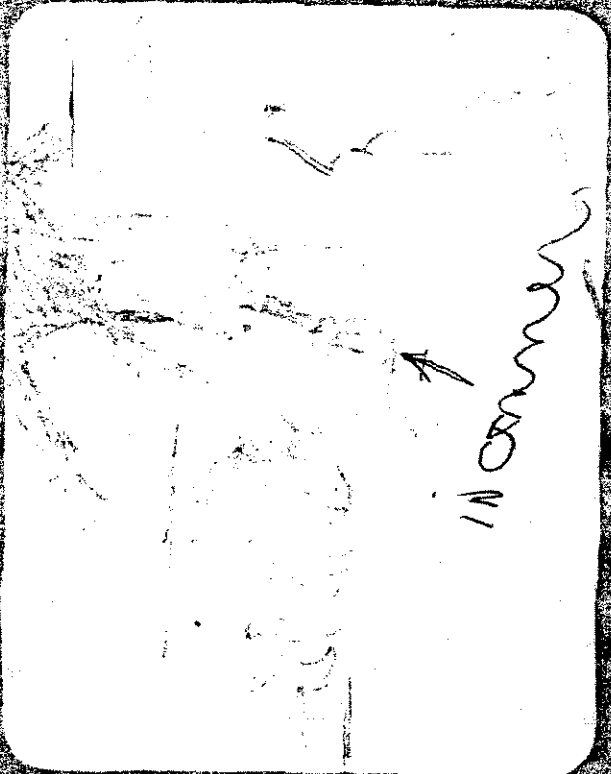

10101
 Don't know
 Don't know

7



10101
 The drawing of
 around him as he
 says to himself
 himself

10

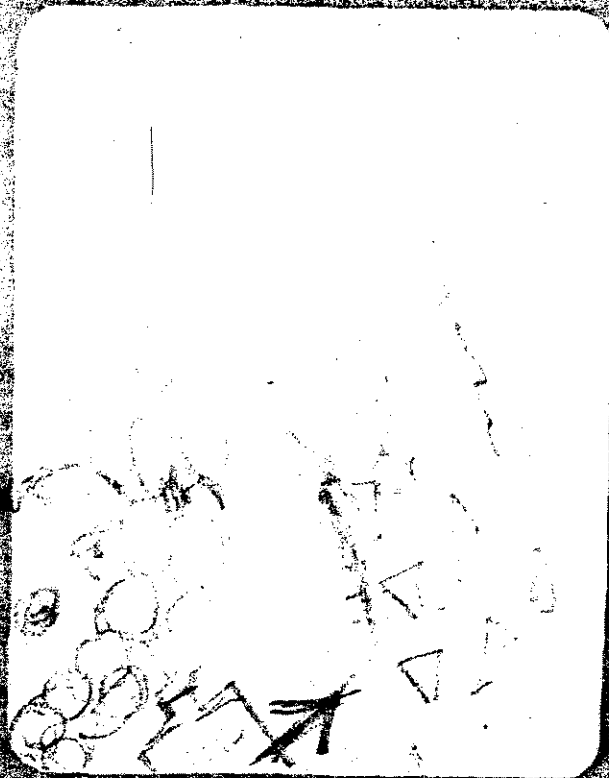

Sc 101
100

9



Sc 101
100
A complete set of
12 bottles of Acid

12



Se 101

... ..
charges
ed
... ..
... ..

11

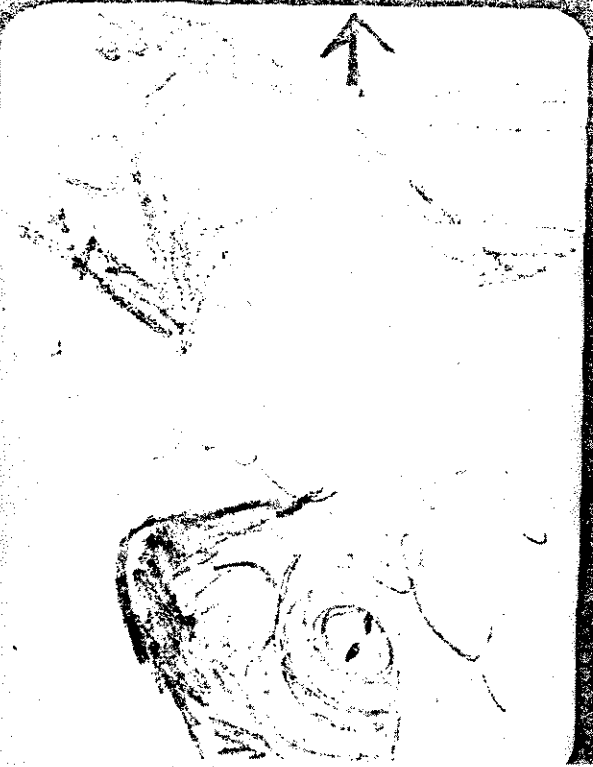

Se 101

Dan
the Body Room
for

14



Sc101 pg 90
 Meg: Daddy!!
 Dan grabs her
 Dan: No! Only us.
 Meg:
 But —

13



Sc101 pg 90
 Hands shoot out of the smoke
 and pull Halsey
 into the clouds of acid
 smoke. Halsey howls.

1



Sc 105

1071

15



Sc 101

1070

We see Walsey being torn
apart through the
swoose (back-lit)

3



Sc 106

11/11
 Dan frantically tries to pull
 it away as the corridor
 doors open and close
 Unsuccessful in disengaging the
 stronghold Dan spots the
 post-like corpse to the
 corridor

1



Sc 106

11/11

Dan pushes the first floor
 button and the doors begin to
 close when a Screaming Corpse
 (Gunn victim) breaks in and
 grabs Meg by the throat

4



Sc 107

16B

Hand held following Ben
in corridor. Ben insures
a fire axe. Smoking glass
grabs the eye and re-enters
the elevator.

2



Sc 106

16B

6



Sc 108 pg 91

Dan hits the Corpse at the
elbow with the axe.
clotted blood spatters the
elevator

5



Sc 108 pg 91

Meg is unconscious as the
Corpse shakes her by the neck
like a broken doll.

8



sc 108 pg 11
Dan kicks the _____
corpse out of the
elevator.

7



sc 108 pg 9
Dan backs away until the
corpse falls away from the
severed arm still gripping
Meg's throat.

10



Sc 108 pg 91

Dan tears the Scared
Arm from Meg's throat
and administers number
Dan: MEG! MEG!
There is no pulse
(Heavy Neck bruising on Meg)

9



Sc 108 pg 91

Dan kicks corpse out of
elevator. Elevator doors
close.
Top view

1



Sc 109 pg 97

Elevator doors open. Dan
 stumbles out carrying
 Meg and the medical
 bag.
 Students run past them
 The fire alarm is ringing.

11



Sc 108 pg 91

Dan begins CPR.
 The arm flops around
 on the floor

5 min
10:50

(60)

RECAMMATOR
GAL & FAUS APART
12-13-84

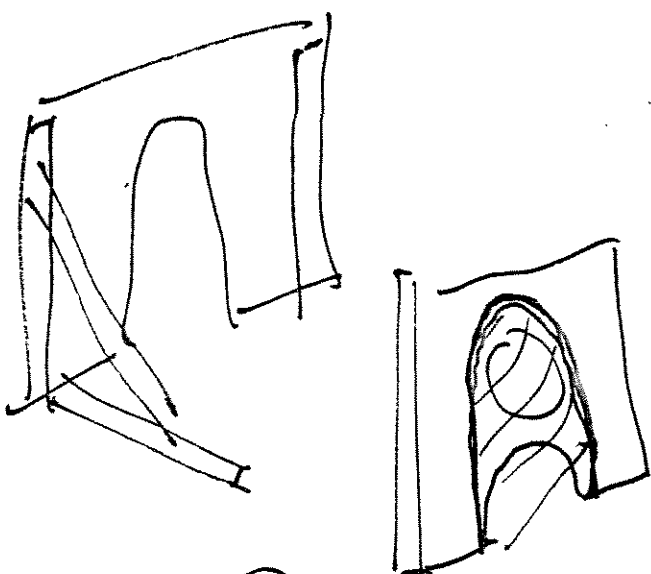
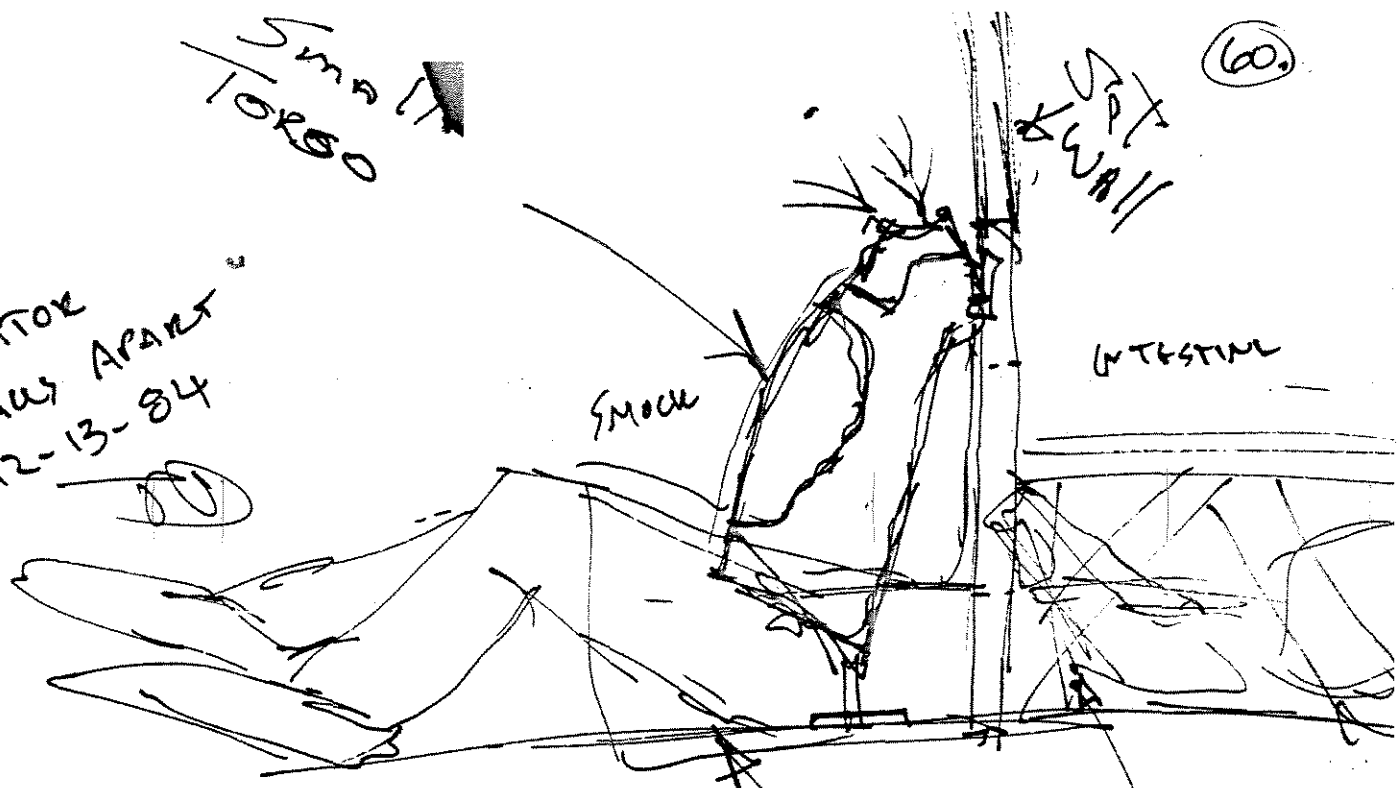

FLOOR
DAVID
HALL

We Need
Interesting Pupp
Beant in

FOR SET...
WHAT WALL'S FLOOR?

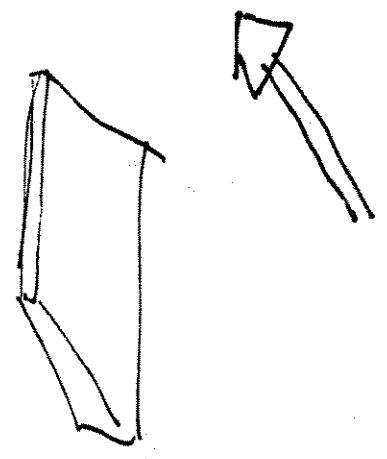
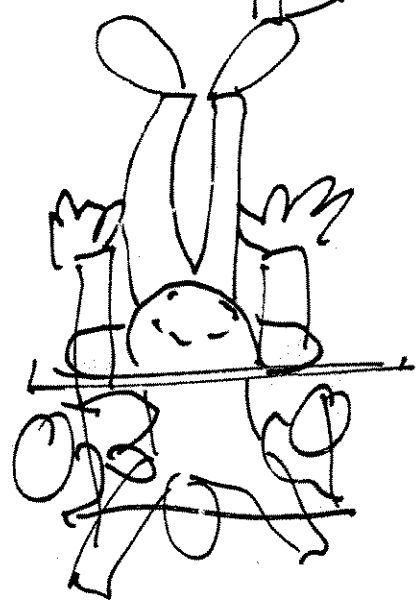

SHEMATICS (61.)
FOR MEFX SPLATTER

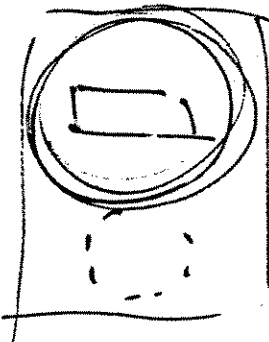
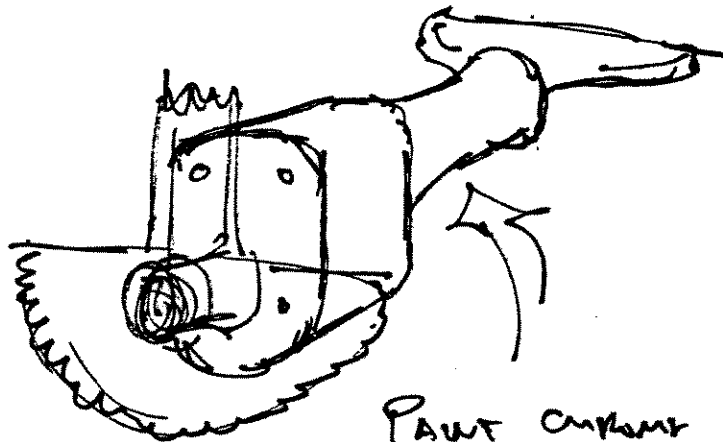
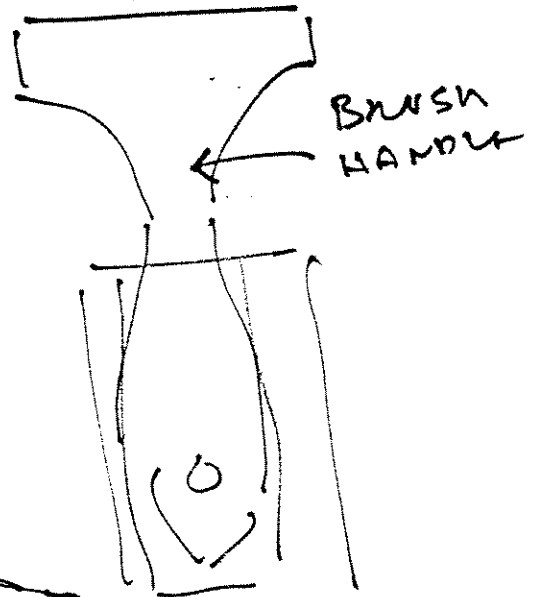
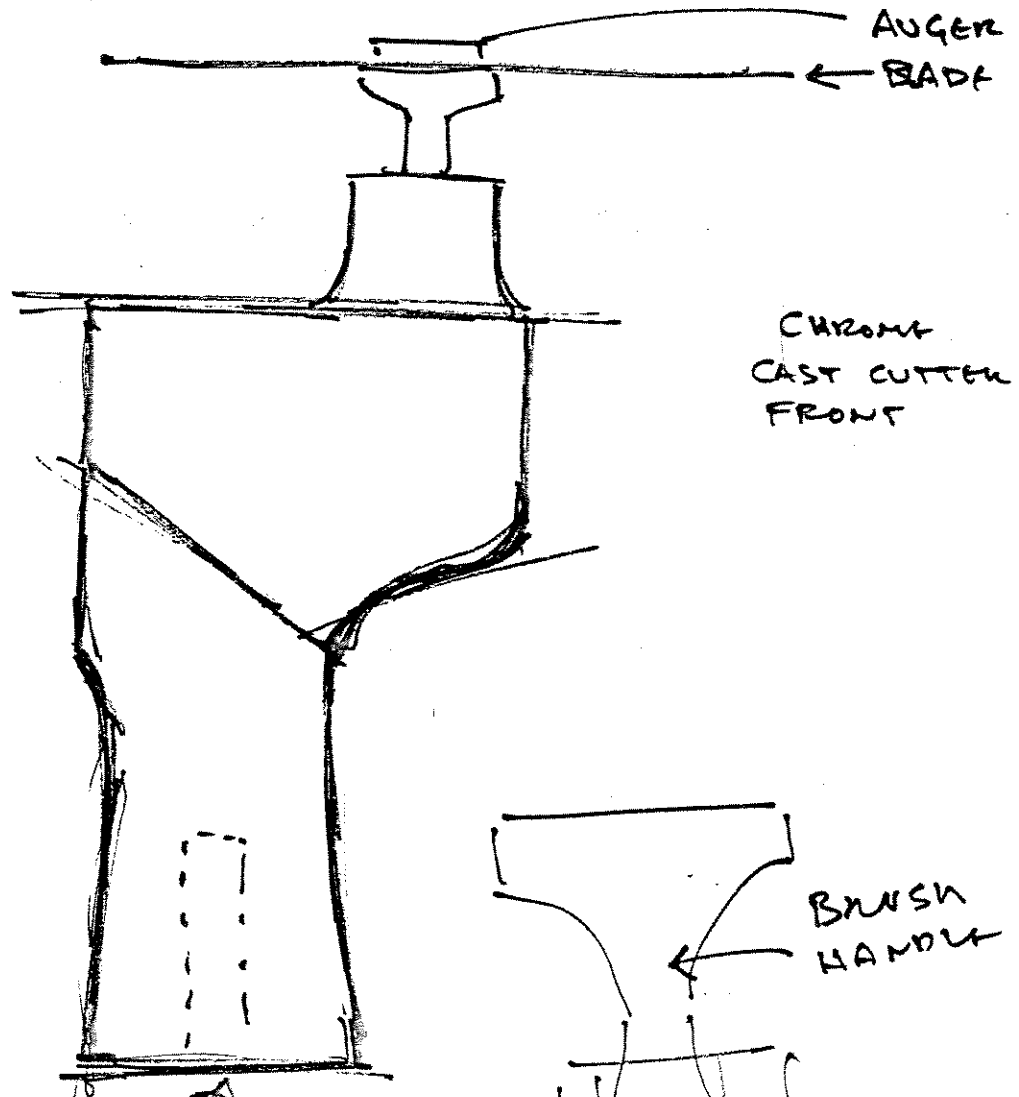

PAINT CUTTERS
(ON ALUMINUM) TO
MATCH EXIST'S

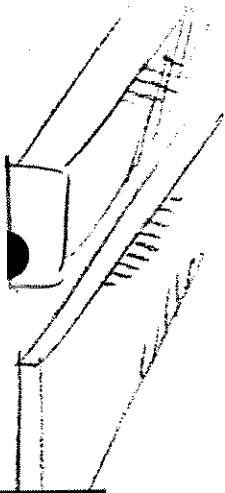

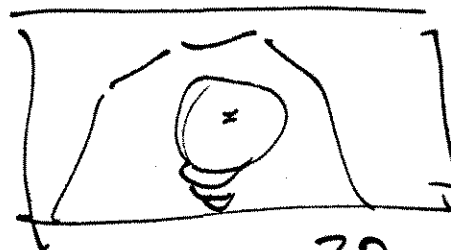
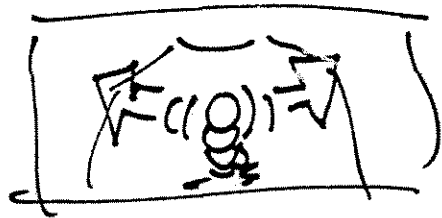
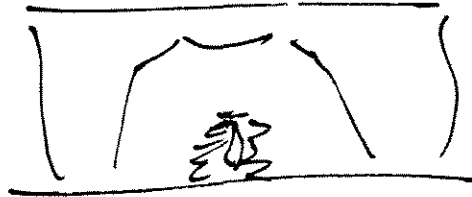
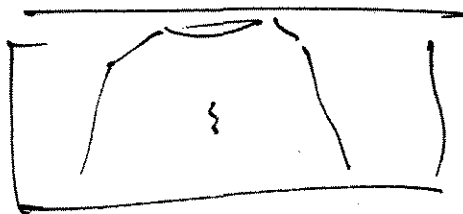
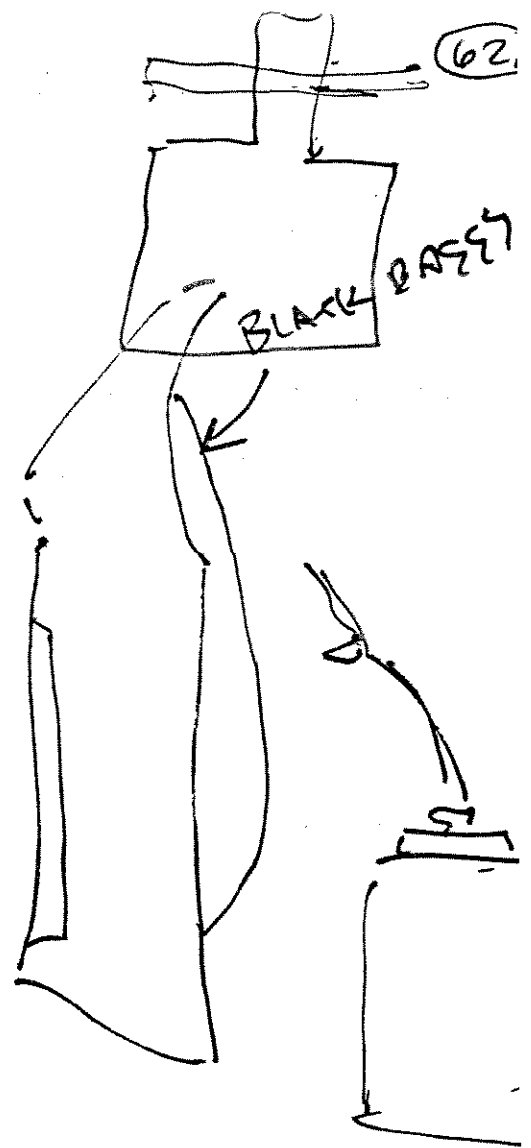
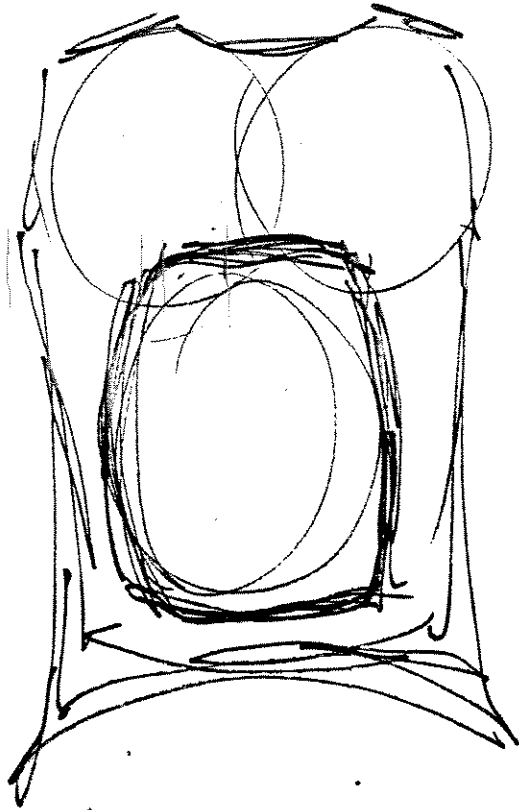
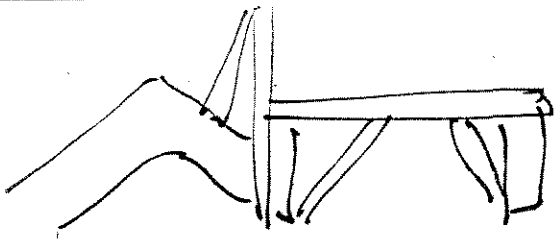

30

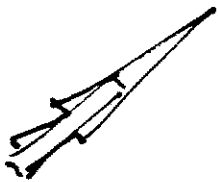

HUDSON
SPRAYER

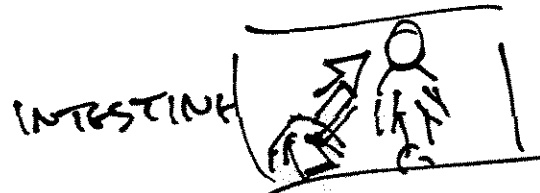

INTERSTINE

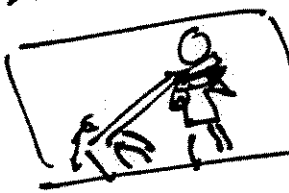

ARM "TIE DOWN" MECHANISM

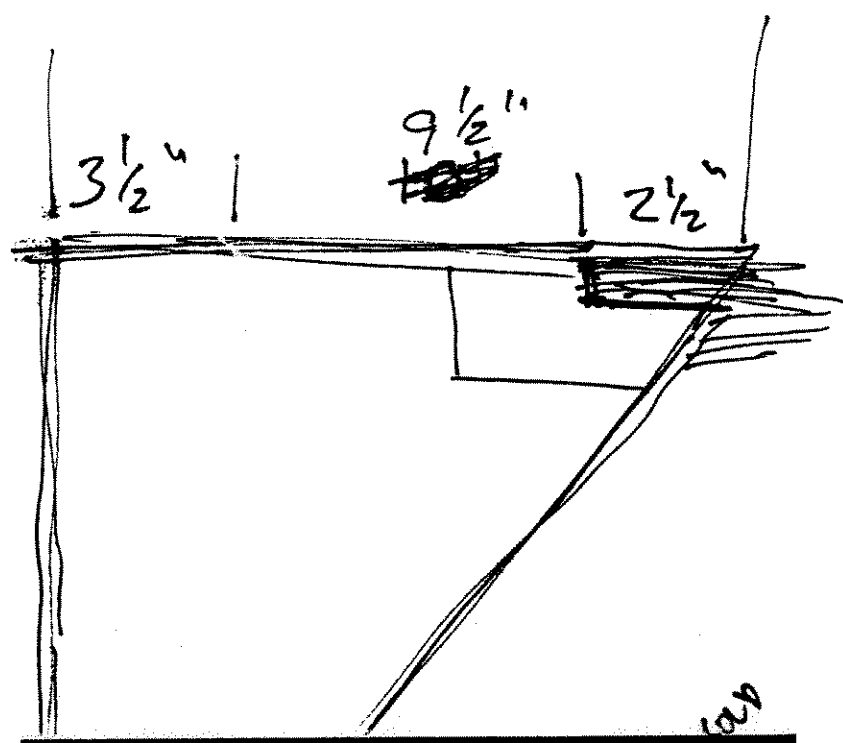
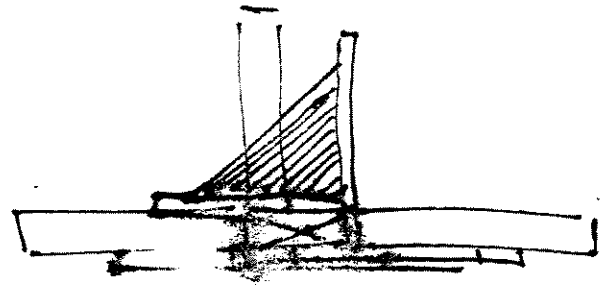
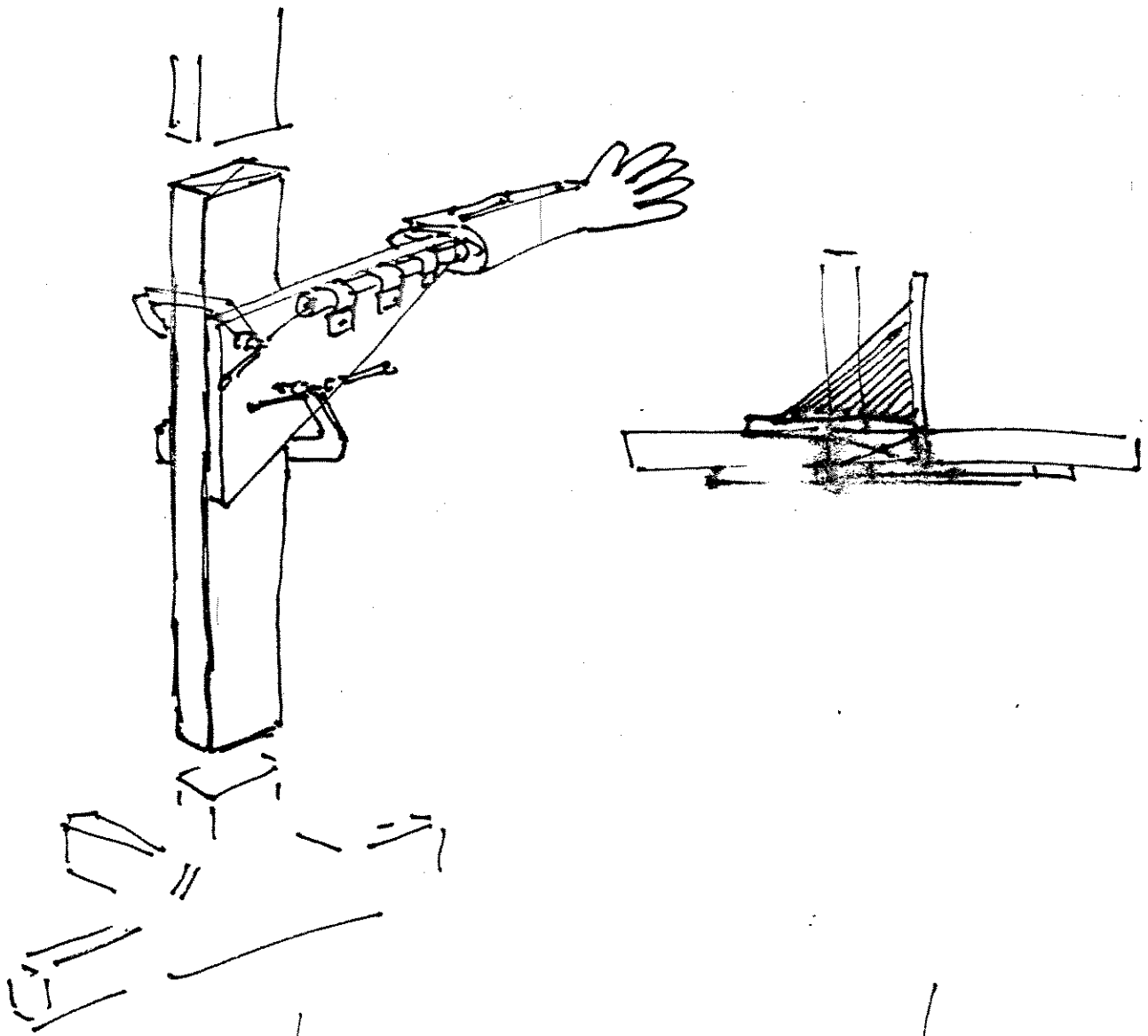

SYRINGE EFX

(04)

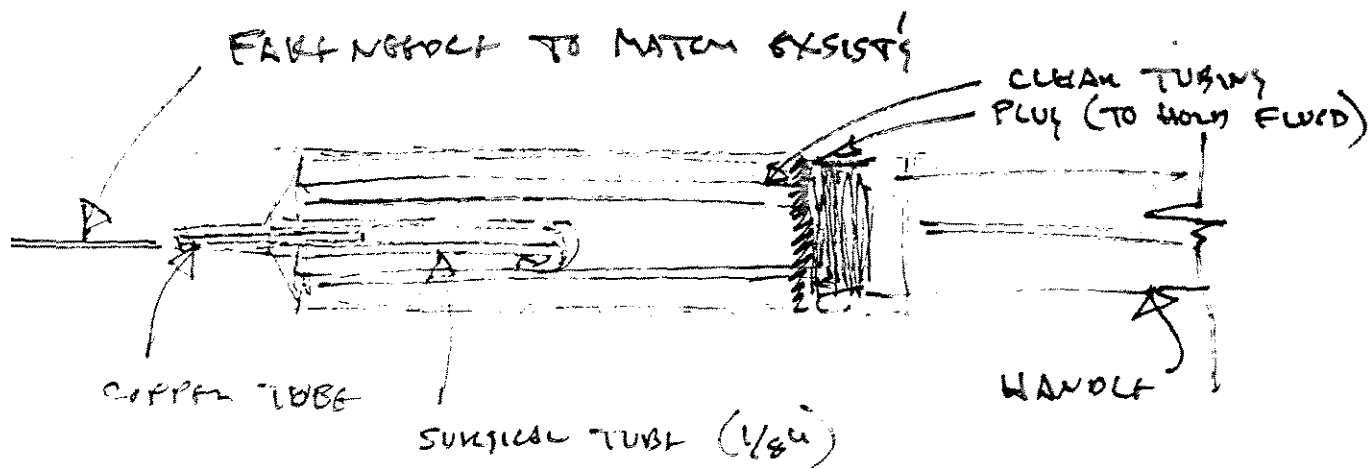

TWO EACH

RETRACTABLE NEEDLE

ONE 20cc & ONE 6cc

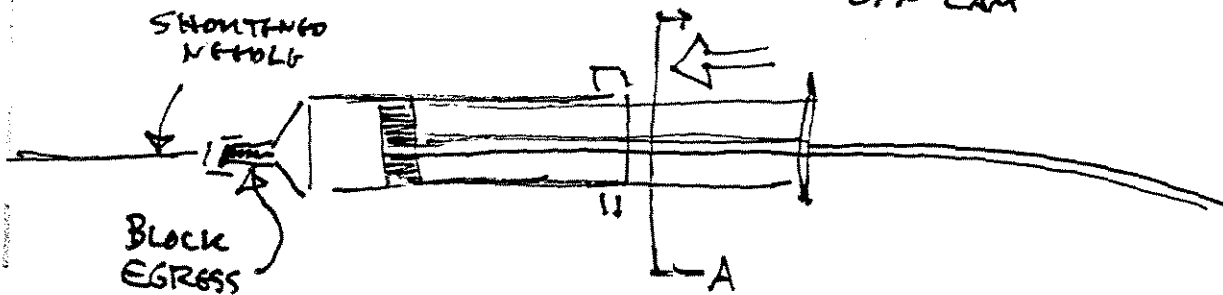
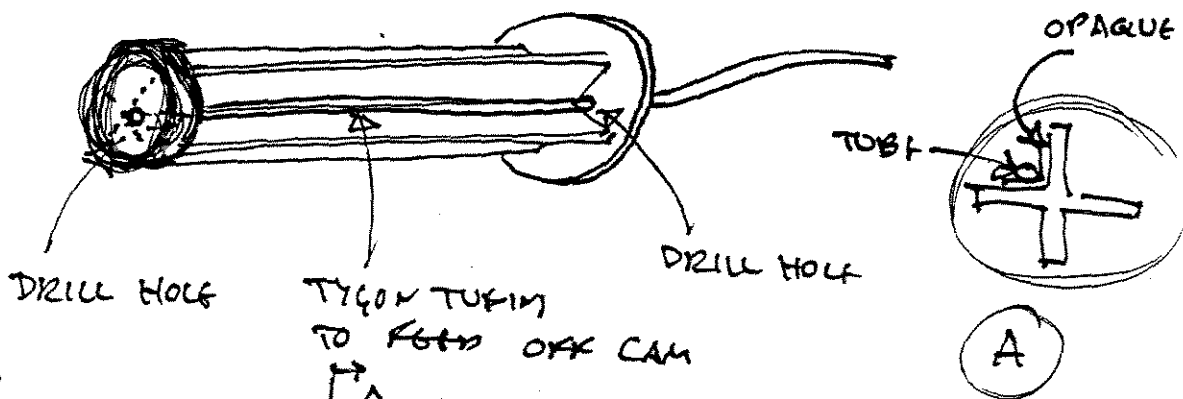

TWO EACH APPLICATING FUNCTIONARY

ONE 20cc & ONE 6cc

NOTE - PAINT NIB ENCLOSURE ON 6cc SILVER

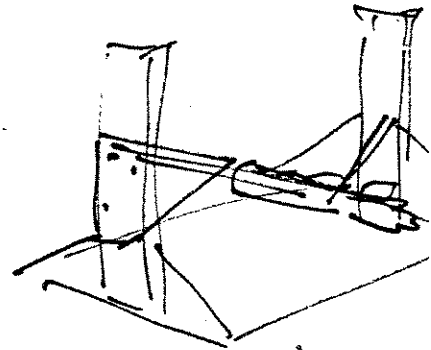
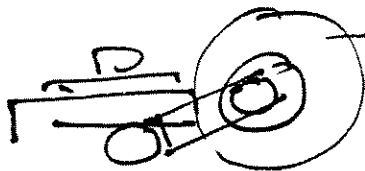
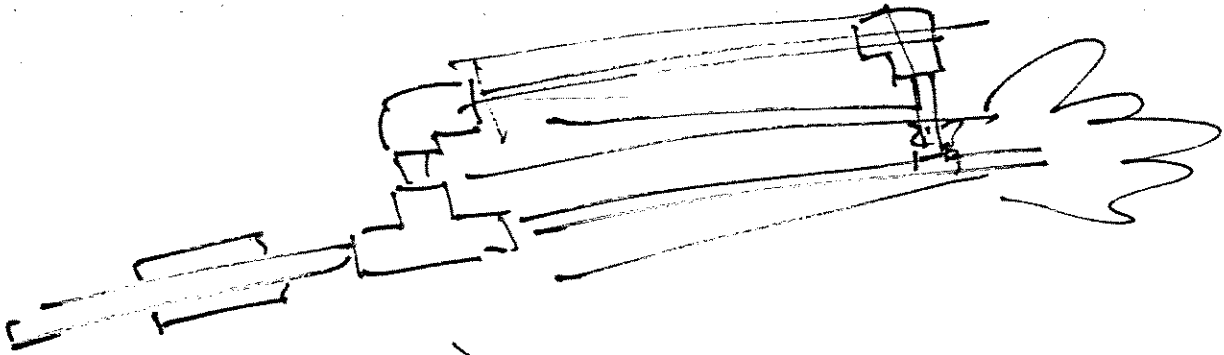

EFX
MFX
SFX

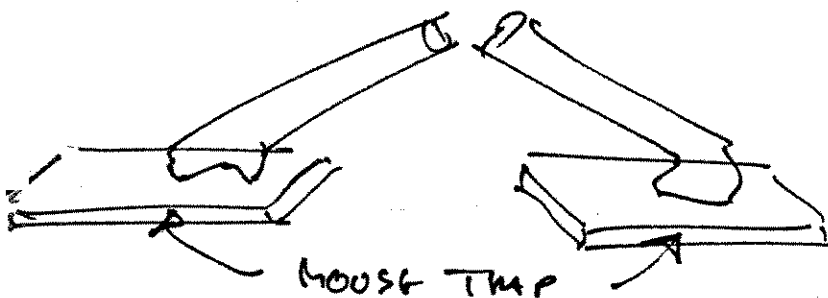
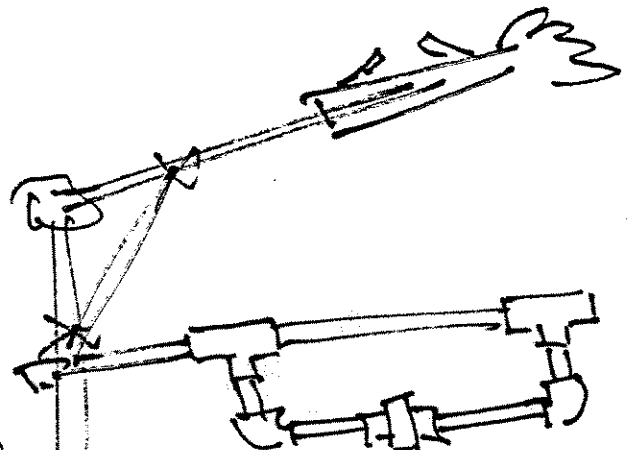
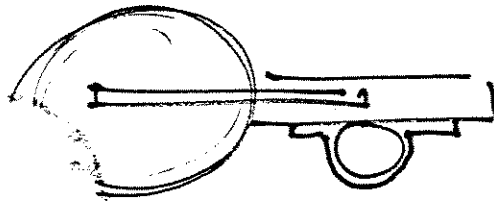

MOUSE TRAP

TRAP MECHANISM

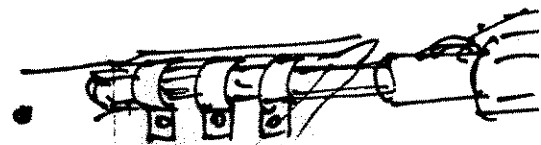

DETAIL REVERSE! (do)

BRICKLAW Door

1262 MORANI

5 ASBESTOS LOSS

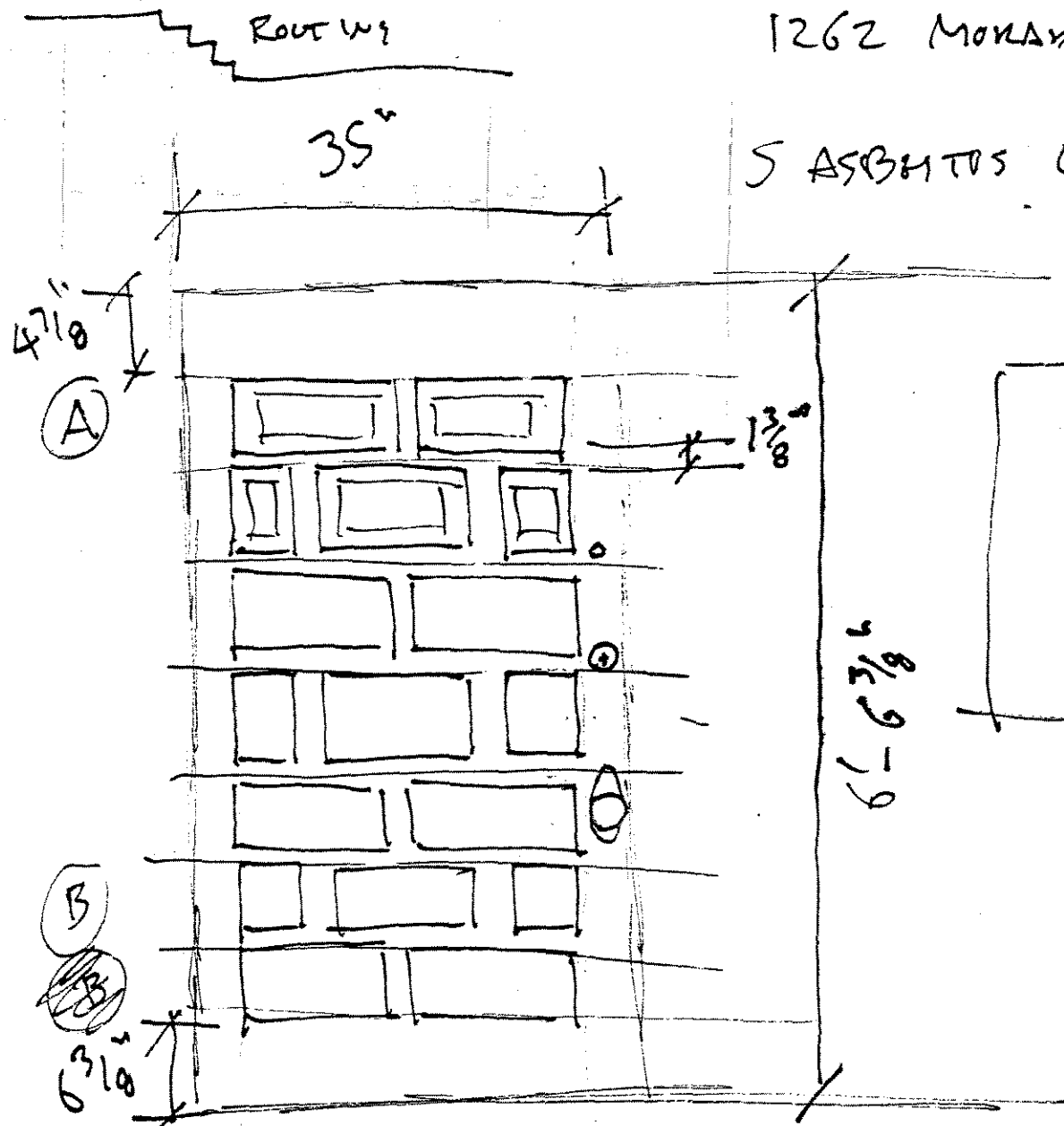

$\frac{3}{4}$
 $\frac{24}{4}$
 $\frac{27}{4}$
 $\frac{5}{5}$

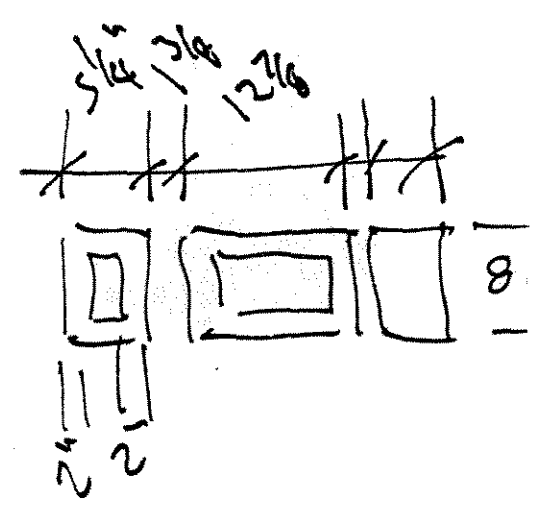
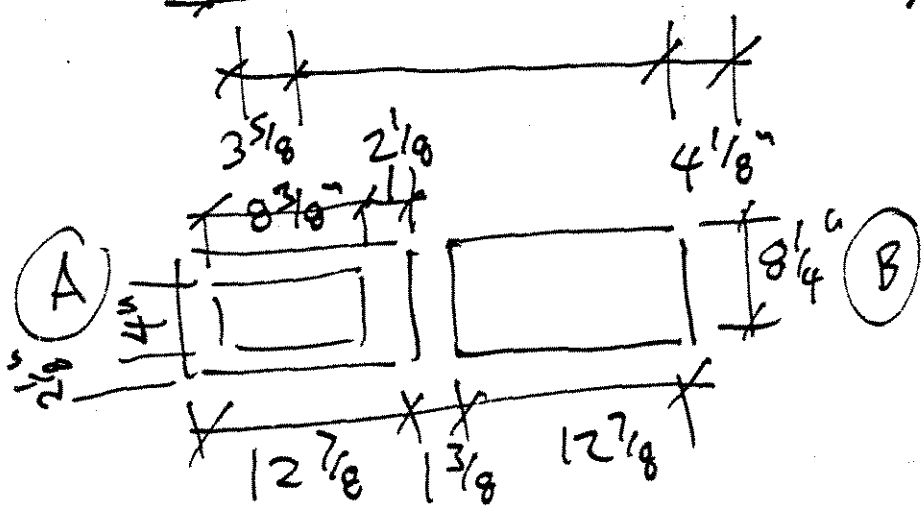

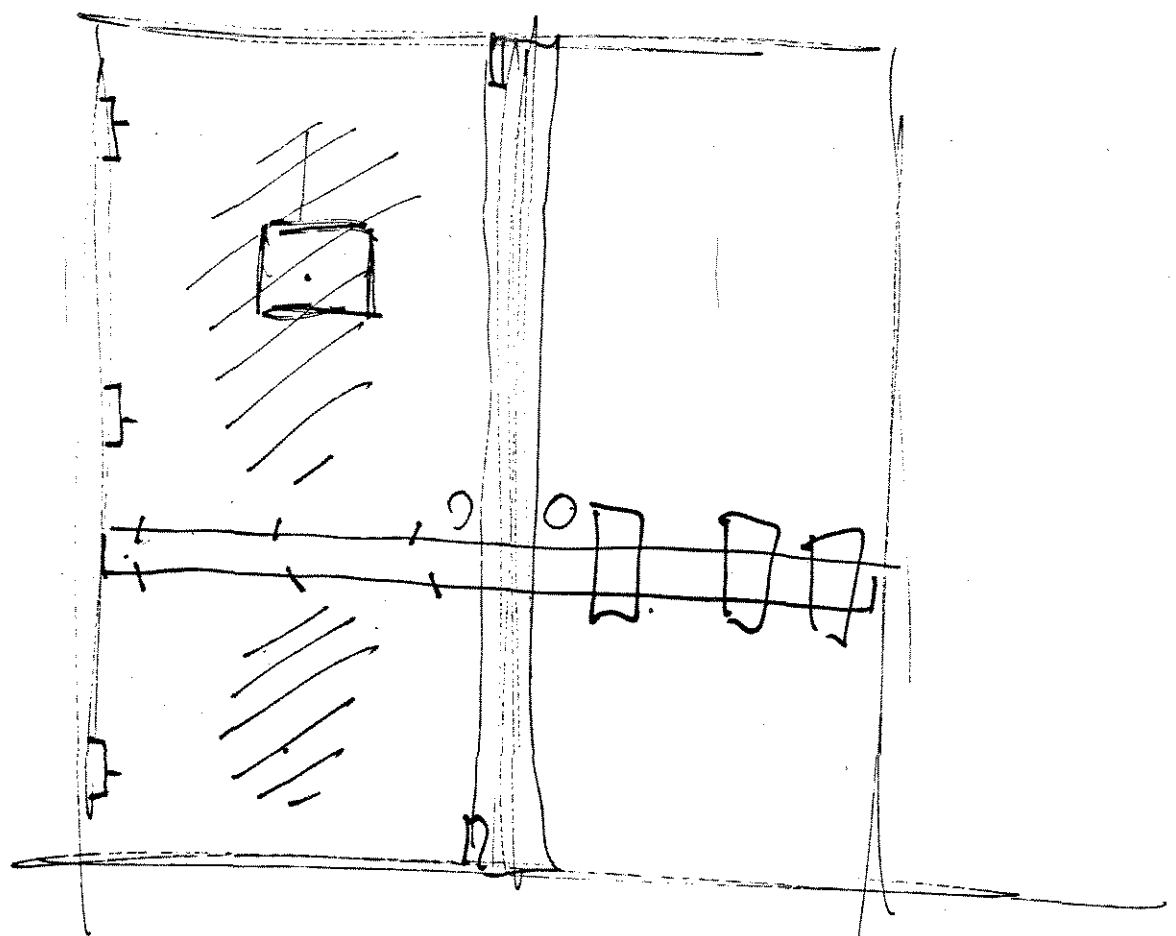

EXTERIOR

WOOD 1" x 6" x 6"

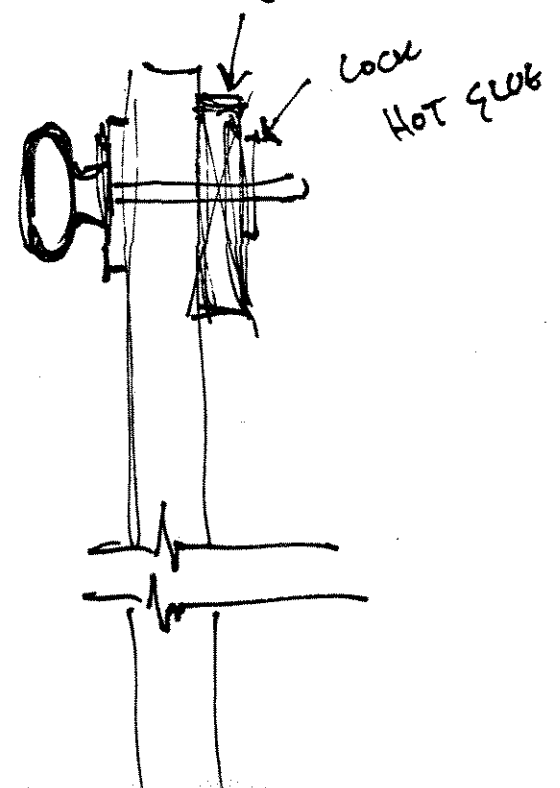
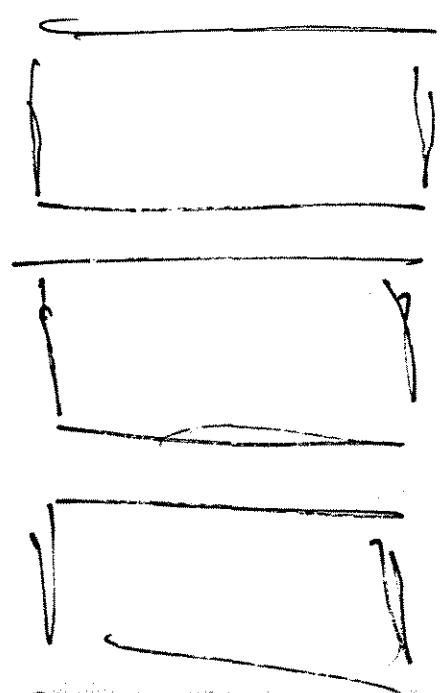

PLYWOOD FOUNDATION OR 1" STOCK

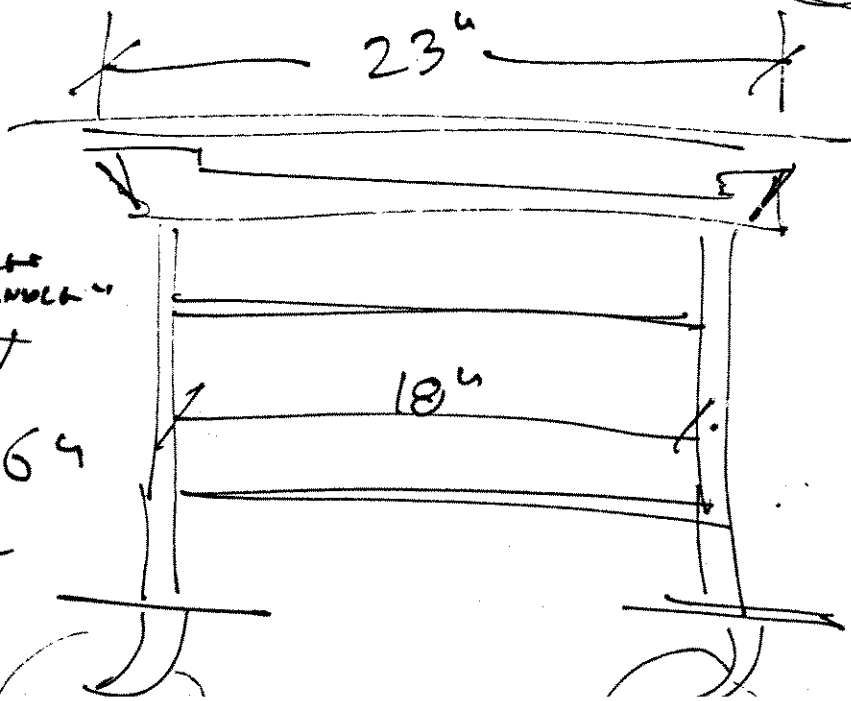
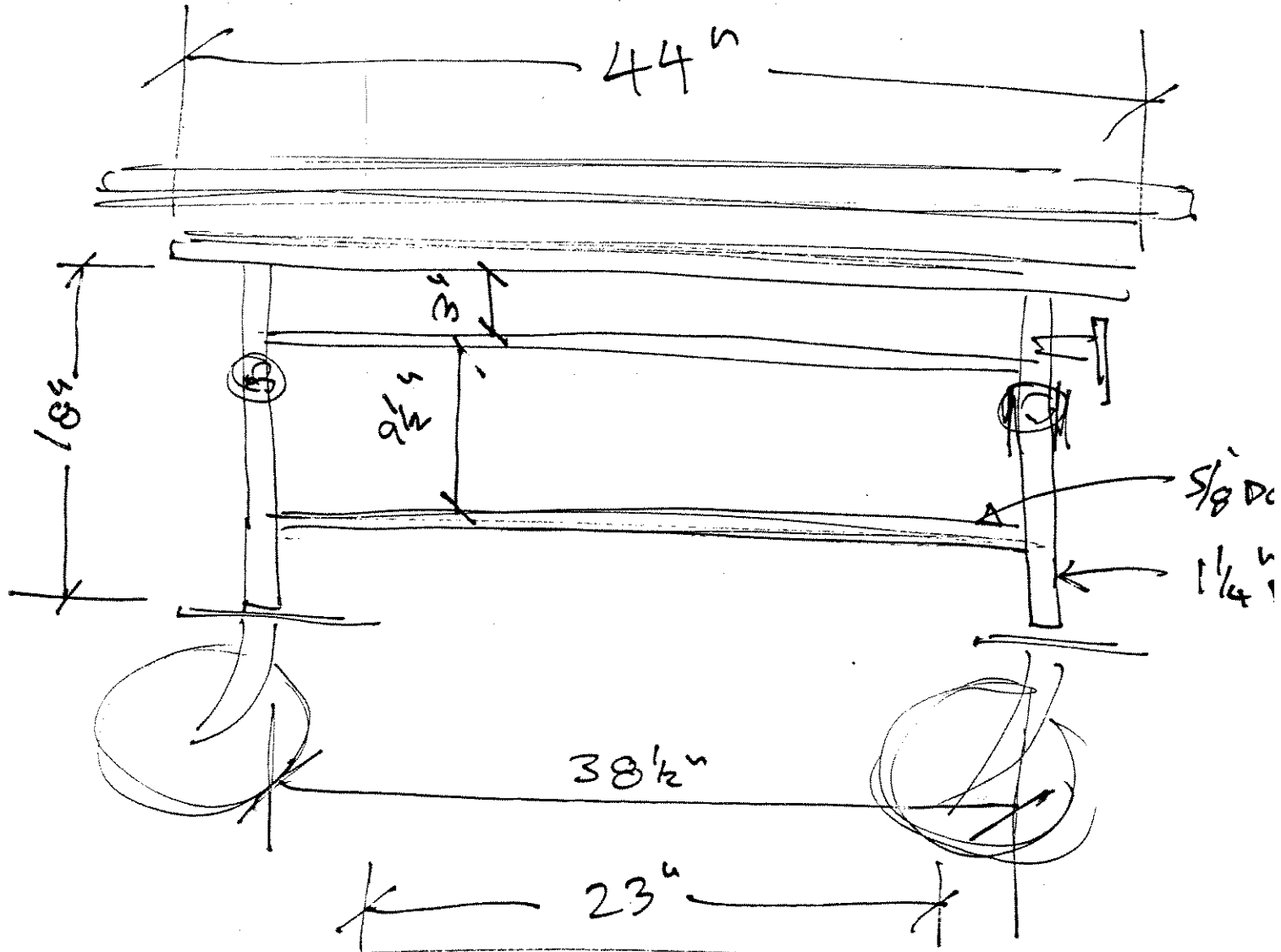
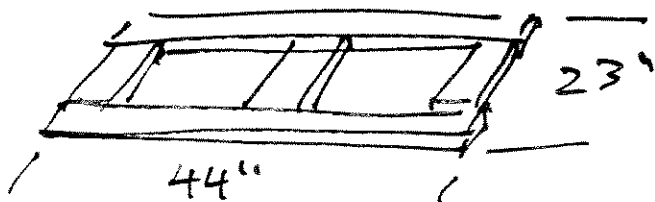

DETAIL

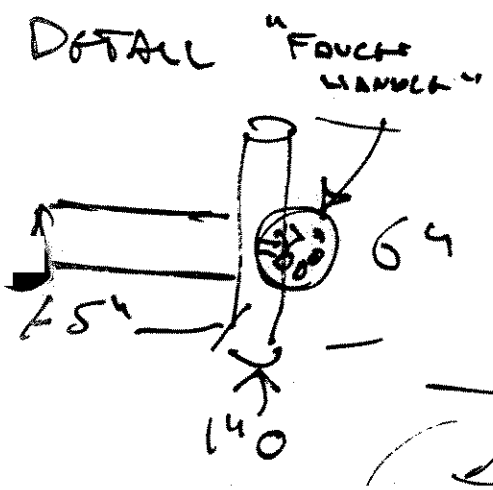

DOWELS

- 4 5/8" x 38 1/2"
- 4 5/8" x 18"
- 4 1 1/4" x 18"
- 2 1" x 6" x 44"
- 3 1" x 6" x 2"

SHOVEL EFX

69.

DISTRESSI

TO MATCH AN OTHER

